



Solar Outdoor Lighting Systems



X-SERIES LED

TECHNICAL SPECS FOR X-35 SOLAR STREET LIGHTING AND SOLAR PATHWAY LIGHTING

LUMINAIRE							
MODEL / LUMEN	6600	9750	13300	14300	16000	PL5550	PL8400
IES LIGHT DISTRIBUTIONS	TYPE 2	TYPE 3	TYPE 5		TYPE 2M	TYPE 3M	TYPE 5S
COLOR TEMPERATURE OPTIONS	3,000K	4,000K	5,000 K	5,700K			
COLOR RENDITIONING INDEX (CRI)	>85 CRI						
MOUNTING	SLIP FITTER		STRAIGHT SQUARE STEEL		CUSTOM		
LED CHIP TYPE	PHILLIPS ILLUMLED 5050 CHIPS						
CLASS RATINGS	CLASS 1 IP66, IK08						
SYSTEM VOLTAGE	INPUT 12/24 VDC - OUTPUT 12/24 VDC						
LUMINAIRE HOUSING	POWDER COATED ALUMINUM, DARK SKY COMPLIANT						
MODULE. **EXACT MODULE WATTAGE MAY VARY DEPENDING ON AVAILABILITY							
CELL TYPE	MONOCRYSTALLINE, UL, CUL, CE LISTED, 25 YEAR PERFORMANCE WARRANTY						
POWER OUTPUT	190-210 W	300-340W	360-390W	400W+			
DIMENSIONS	1580 MM X 808 MM	1960 MM X 990 MM	1987 X 999 MM	1500MM X 1616MM			
BATTERY ENCLOSURE							
	ALUMINUM NEMA 3R						
	ANTI-THEFT SECURITY SCREWS						
	PREWIRED AND TESTED						
	POWDER COATED FOR HARSH MARINE ENVIRONMENT						
	RAISED RIDGED RUBBER BATTERY MAT FOR THERMAL PROTECTION						
ELECTRONICS \ CONTROLLER							
CONTROLLER	PRE-WIRED AND MOUNTED IN BATTERY ENCLOSURE						
	DUAL CIRCUIT BREAKER PROTECTED, NO FUSE REPLACEMENT						
	MAXIMUM POWER POINT TRACKING (MPPT) CHARGE CONTROLLER						
	REVERSE POLARITY PROTECTED						
	* BLUETOOTH PROGRAMMING AND MONITORING SYSTEM AND PHONE APP CONTROL FOR ANDROID AND IPHONE						
	EN/IEC 62109-1, UL 1741 CSA C22.2						
CIRCUIT BREAKERS	DC RATED, UL LISTED, DIN RAIL MOUNTABLE						
SOLAR PANEL MOUNTING							
	TOP OF POLE ALUMINUM MOUNT		SIDE OF POLE ALUMINUM MOUNT				
	COMPLETELY ADJUSTIBLE, NON FIXED		ADJUSTABLE				
BATTERY MADE IN USA							
	MAINTENANCE FREE GEL BATTERY						
OPERATING TEMP	-76F - 140F						
RATING	3,000 CYCLES @ 25% DOD						
BACKUP	3 DAY		5 DAY				
POLE DATA							
EPA	16		26		32		
TENON	2" / 60 MM SCHED 40		3" / 89MM SCHED 40		4" / 114MM SCHED 40		
SYSTEM COLORS	SILVER GREY		BLACK				
TYPE	DIRECT BURIAL		CONCRETE PIER				
ARM	8"		CUSTOM				
COMPOSITION	COMP. FIBERGLASS		HDG		CUSTOM		
WIND LOAD RATING	100 MPH		120 MPH		130 MPH		
	150 MPH		170 MPH				
POLE HEIGHT - ABOVE GRADE	CUSTOMER SPECIFIED						



SLI-80W

LED Street & Parking Lot Light, 400W HID Replacement

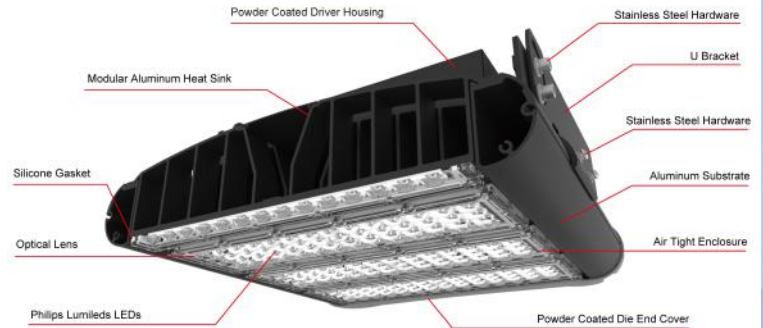

Black / white / silver / bronze color housing optional
1-10V / PWM / Resistance dimming optional

Specifications

Electrical Specifications

Model No.	SLI-80W
Nominal Wattage	80W
Nominal Voltage	90-305/277-480VAC, 50/60Hz
	24VDC
Maximum Current	AC 0.9A (max) DC 0.3A (max)
Power Factor (PF)	>0.95
Driver Efficiency	>92%

Photometric Specifications

Luminous Flux	+Lumen tolerance +/- 5% 13000lm+
CRI	Ra>75
CCT	3000-6500K
Optional Beam Angle	60°/150° / 70°/150° / 80°/150° / 90°/100° / 60° / 120°

Mechanical Specifications

IP&IK Rating	IP66 & IK10
Lifetime	62000 hours - L70, @25°C
Heat Radiator	Anodized Aluminum
Lens	PC
Fixture Dimension	576*300*107mm 22.7*11.8*4.2 inches
Net Weight	7.5kg
Carton Dimension	650*370*190mm
Gross Weight	8.3kg

Photometrics

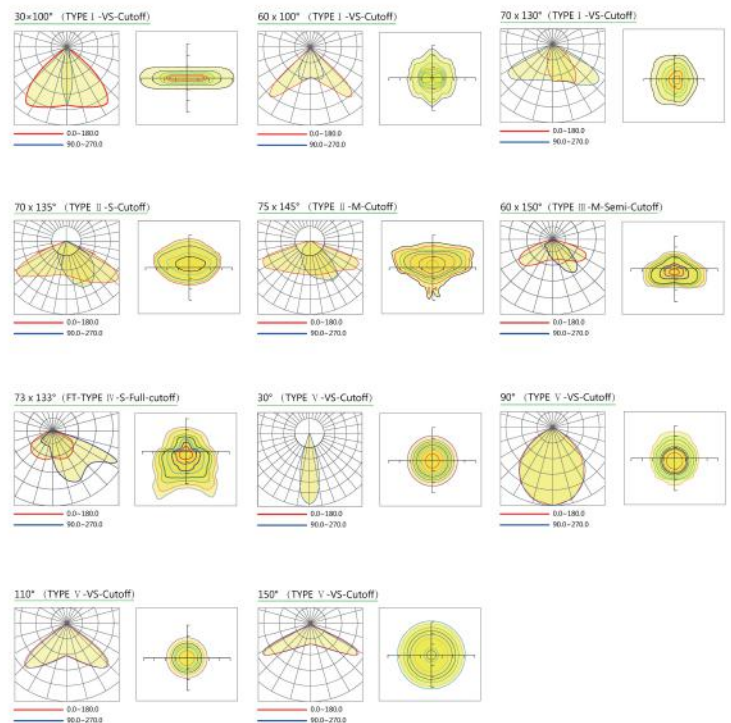

Product Benefits

PHILIPS LUMILEDS LED LUMINOUS SOURCE

The new SLI Series LED street light utilizes a PHILIPS LUXEON® LED luminous source, providing excellent lumen output, long-lasting stability and splendid sight.

Each PHILIPS LUXEON® T chip owns electrostatic protection component, maximally avoid the damage of electrostatic.

More information about the PHILIPS LUXEON® Rebel ES and solid-state lighting technologies can be found at www.philipslumileds.com.

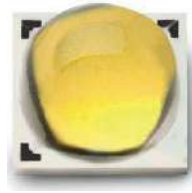

- Superior efficacy
- Leading lumen output
- Ultimate design flexibility



MW MEAN WELL LED DRIVER

Full range SLI Series LED street light utilizing MeanWell HLG Series high-end driver. Providing great luminaire stability, lifespan and optimal performance status.

More information about the MeanWell HLG Series and LED driver technologies, please visit www.meanwell.com



BRAND-NEW LED MODULE DESIGN

Exquisite design with powerful thermal output, with more reliable waterproof performance.



HYUNDAI SOLAR MODULE

RI
SERIES

Multi-Crystalline Type

HiS-M310RI HiS-M315RI HiS-M320RI

Mono-Crystalline Type

HiS-S330RI HiS-S335RI HiS-S340RI HiS-S345RI
HiS-S350RI HiS-S355RI HiS-S360RI

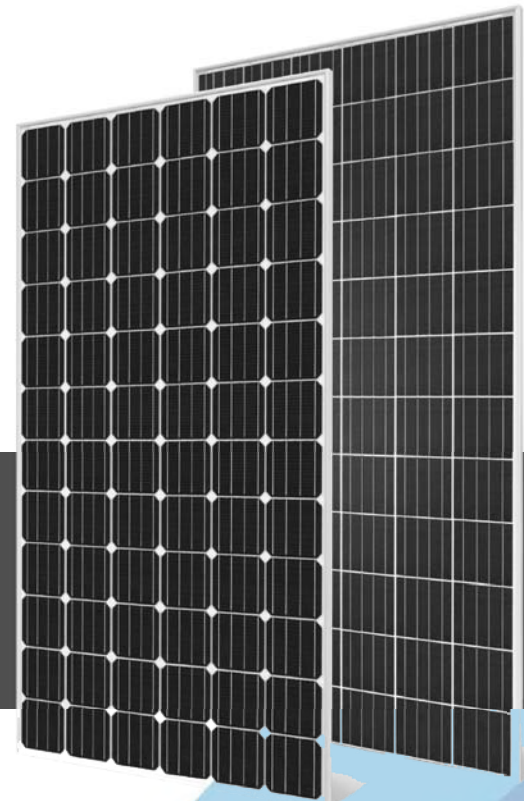

72

Cells



For Commercial & Utility Applications



More Power Generation In Low Light

MADE IN KOREA

Hyundai Cell, Made in Korea



PERL Technology

PERL technology provides ultra-high efficiency with better performance in low irradiation. Maximizes installation capacity in limited space.



Low LID / PID

Both LID(Light Induced Degradation) and PID(Potential Induced Degradation) are strictly eliminated to ensure higher actual yield during lifetime.



Mechanical Strength

Tempered glass and reinforced frame design withstand rigorous weather conditions such as heavy snow and strong wind.



Reliable Warranty

Global brand with powerful financial strength provide reliable 25-year warranty.



Corrosion Resistant

Various tests under harsh environmental conditions such as ammonia and salt-mist passed.



UL / VDE Test Labs

Hyundai's R&D center is an accredited test laboratory of both UL and VDE.

Hyundai's Warranty Provisions



- 10-Year Product Warranty
- On materials and workmanship



- 25-Year Performance Warranty
- 90% of guaranteed min. power for 10 years
- 80% of guaranteed min. power for 25 years

About Hyundai Solar

Established in 1972, Hyundai Heavy Industries (HHI) is one of the most trusted names in the heavy industries sector with 48,000 employees and more than 40 Billion USD in annual sales (2015). As a global leader and innovator, Hyundai Heavy Industries is committed to building a future growth engine by developing and investing heavily in the field of renewable energy.

Started as a core business division of HHI, Hyundai Solar (Hyundai Heavy Industries Green Energy) now stands as an independent company and an affiliate of HHI as from December 2016. It is the largest and the longest standing PV cell and module manufacturer in South Korea with 800 MW of module production capacity. We have strong pride in providing high-quality solar PV products to more than 3,000 customers worldwide.

Certification



Electrical Characteristics

		Multi-Crystalline Module (HiS-M Ri)			Mono-Crystalline Module (HiS-S Ri)						
		310	315	320	330	335	340	345	350	355	360
Nominal Output (P _{mpp})	W	310	315	320	330	335	340	345	350	355	360
Open Circuit Voltage (V _{oc})	V	45.3	45.3	45.5	46.3	46.5	46.7	46.9	47.1	47.3	47.4
Short Circuit Current (I _{sc})	A	8.9	9.0	9.0	9.3	9.4	9.5	9.6	9.6	9.7	9.8
Voltage at P _{max} (V _{mpp})	V	36.0	36.2	36.4	38.0	38.2	38.4	38.6	38.7	38.9	39.1
Current at P _{max} (I _{mpp})	A	8.6	8.7	8.8	8.7	8.8	8.9	9.0	9.0	9.1	9.2
Module Efficiency	%	15.8	16.1	16.4	16.9	17.1	17.4	17.6	17.9	18.1	18.4
Cell Type	-	6", multi-crystalline silicon			6", mono-crystalline silicon						
Maximum System Voltage	V	1,000			1,000						
Temperature coefficient of P _{max}	%/K	-0.41			-0.40						
Temperature coefficient of V _{oc}	%/K	-0.31			-0.29						
Temperature coefficient of I _{sc}	%/K	0.039			0.039						

*All data at STC (Standard Test Conditions). Above data may be changed without prior notice.

Mechanical Characteristics

Dimensions	998 mm (39.29") (W) x 1,960 mm (77.17") (L) x 40 mm (1.57") (H)
Weight	Approx. 22.9 kg (50.5 lbs)
Solar Cells	72 cells in series (6 x 12 matrix) (Hyundai cell, Made in Korea)
Output Cables	4 mm ² (12AWG) cables with polarized weatherproof connectors, IEC certified (UL listed and UL 4703 certified), Length 1.2 m (47.2')
Junction Box	IP67, weatherproof, IEC certified (UL listed)
Bypass Diodes	3 bypass diodes to prevent power decrease by partial shade
Construction	Front : Anti-reflection coated glass, 3.2 mm (0.126") Encapsulant : EVA Back Sheet : Weatherproof film
Frame	Clear anodized aluminum alloy type 6063

Installation Safety Guide

- Only qualified personnel should install or perform maintenance.
- Be aware of dangerous high DC voltage.
- Do not damage or scratch the rear surface of the module.
- Do not handle or install modules when they are wet.

Nominal Operating Cell Temperature	46°C ± 2
Operating Temperature	-40 – 85°C
Maximum System Voltage	DC 1,000 V (IEC) DC 1,000 V (UL)
Maximum Reverse Current	15A (Up to 350W) 20A (Above 355W)

Module Diagram (unit : mm)

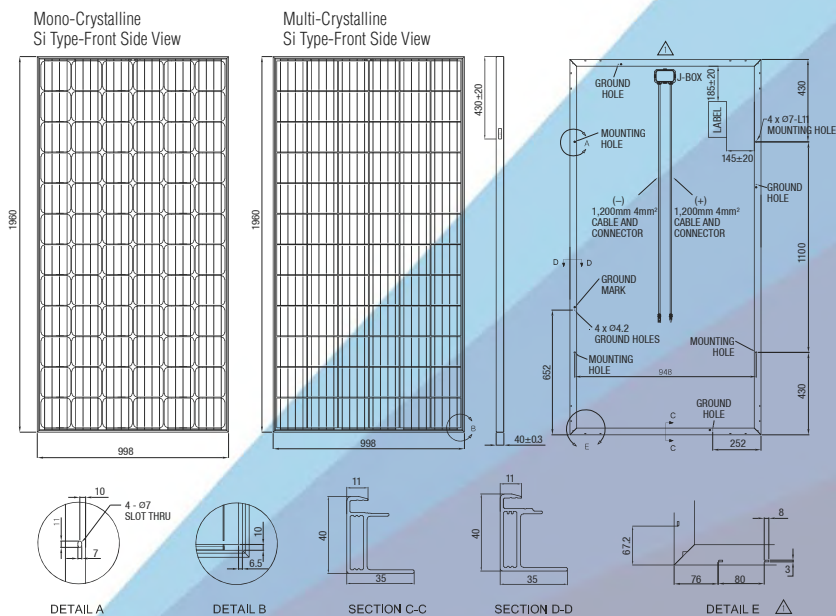

I-V Curves

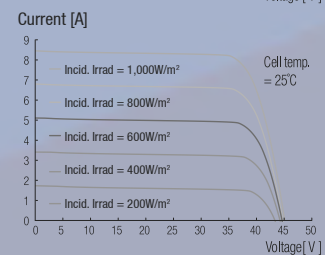
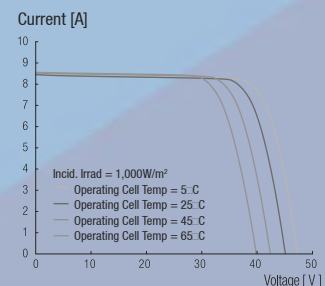

HYUNDAI
GREEN ENERGY

MOUNTS: 1X-TPM-series



Top-of-Pole Mounting (TPM) :

SLI, Inc. manufactures and distributes a complete line of mounting kits to accommodate a wide range of off-grid applications. From single module top-of-pole mounts to complex multi-panel arrays, our mounting line has the flexibility to meet your mounting needs.

Our Top-of-Pole Mounts Feature:
Rugged Materials and Construction,
Precision Engineering and Expert Support

Pole Selection:

- Determine solar panel or solar array area (SQ. FT)
- Select pole size based on selection guidelines in Table 1.
- Solar Lighting International, Inc. does not supply poles with our mounting kits).

Top-of-Pole : Guidelines For Pole Selection

Module Area	Pole Size	Depth In Ground	Height Above Ground	Hole Diameter
15 SQ. FT.	2" SCH40 (2-3/8" OD)	30"-36"	48"-72"	8"-12"
28 SQ. FT.	3" SCH40 (3-1/2" OD)	36"-42"	48"-72"	12"-16"
35 SQ. FT.	3" SCH40 (3-1/2" OD)	38"-44"	60"-72"	12"-16"
60 SQ. FT.	4" SCH40 (4-1/2" OD)	42"-48"	60"-72"	16"-24"
90 SQ. FT.	6" SCH40 (6-5/8" OD)	48"-60"	60"-84"	24"-30"
120 SQ. FT.	6" SCH40 (6-5/8" OD)	48"-72"	72"-84"	24"-30"



1X-TPM Series:

- Available for 2",3",4" and 6" SCH 40 pipe

Table 1

* Module Area (SQ. FT) = W (Panel Width in FT) x L (Panel Length in FT)

* Solar Array Area (SQ. FT) = W (Panel Width in FT) x L (Panel Length in FT) x Number of Panels per Array

Photographs are intended to portray typical mount appearance, actual appearance may vary.

- ① Panel Kit Rail
- ② Solar Panel
- ③ L-Bracket (Foot)
- ④ Cross Pipe
- ⑤ Pipe End Cap
- ⑥ U-Bolt with Saddle Bracket

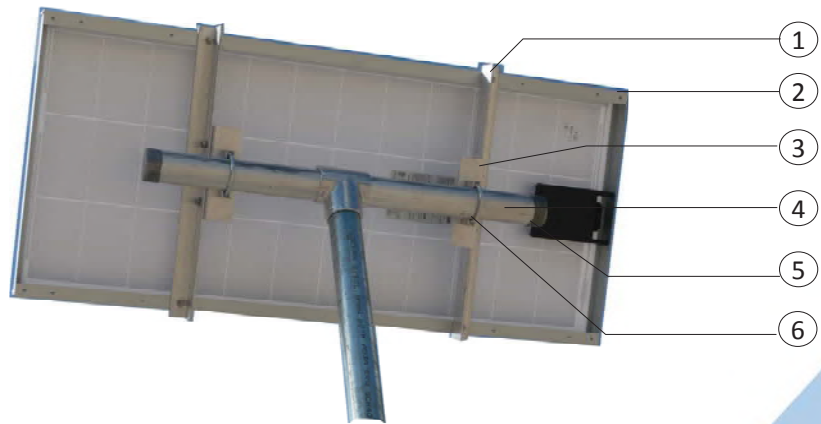

Figure 1. Mounting kit components

Attachment to Panel Kit Rail

Attachment to Cross Pipe

Array Tilt Angle Selection:

SITE LATITUDE: (In Degrees)	FIXED TILT ANGLE
0° TO 15°	15°
15° TO 25°	SAME AS LATITUDE
25° TO 30°	SAME AS LATITUDE +5°
30° TO 35°	SAME AS LATITUDE +10°
35° TO 40°	SAME AS LATITUDE +15°
40° +	SAME AS LATITUDE +20°

Table 2.

Figure 2. Use L-brackets to attach to the panel kit rails and to cross pipe.

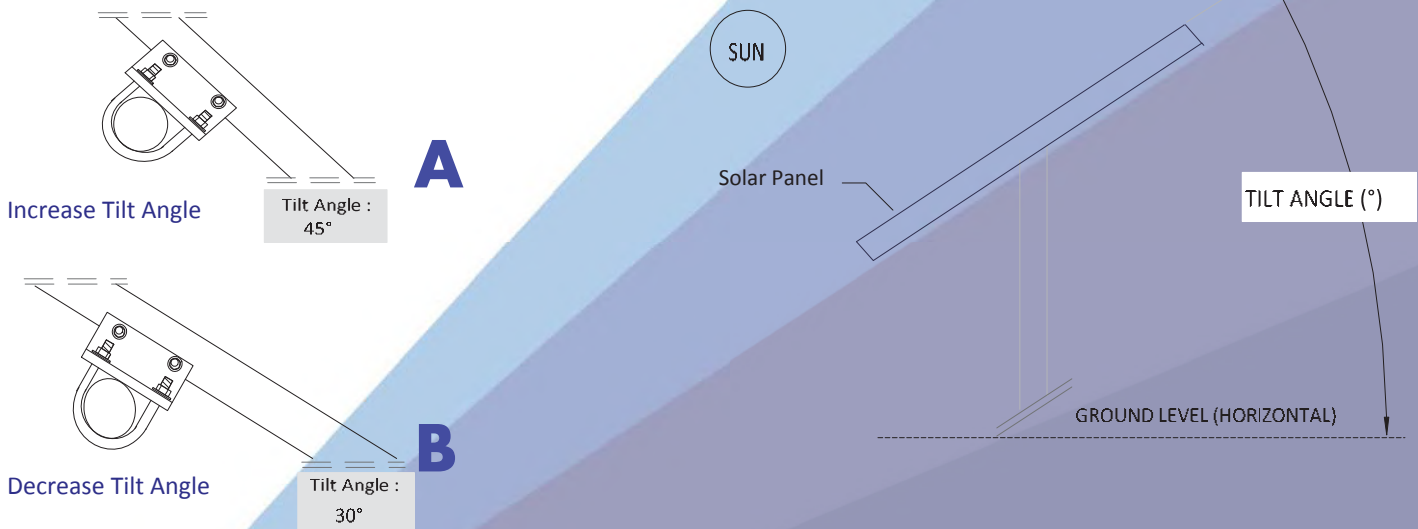

Figure 3. Tilt Angle Adjustments: Adjust PV Array Tilt Angle by rotating U-bolts to desired angle.

Locate array in an unshaded area facing equator and tilted from the horizontal at desired tilt angle (See Table 1).
 Solar arrays in the Northern Hemisphere face South for optimum energy production. Solar Arrays in the Southern hemisphere face North.
 When choosing a site, avoid trees, overhead power lines, buildings or obstructions which could cast shadows on the solar modules.
 This is especially true during the winter months when the arc of the sun is lowest to the horizon.

Bluetooth SmartSolar Charge Controllers with load output

MPPT 75/10, 75/15, 100/15, 100/20, 100/20-48V



Bluetooth Smart built-in:

The wireless solution to set-up, monitor and update the controller using Apple and Android smartphones, tablets or other devices.

SLI.Direct

For a wired data connection to a Color Control panel, PC or other devices

Ultra-fast Maximum Power Point Tracking (MPPT)

Especially in case of a clouded sky, when light intensity is changing continuously, an ultra-fast MPPT controller will improve energy harvest by up to 30% compared to PWM charge controllers and by up to 10% compared to slower MPPT controllers.

Load output

Over-discharge of the battery can be prevented by connecting all loads to the load output. The load output will disconnect the load when the battery has been discharged to a pre-set voltage (48V model: interface with a relay).

Alternatively, an intelligent battery management algorithm can be chosen: see Battery Life.

The load output is short circuit proof.

Battery Life: Intelligent battery management

When a solar charge controller is not able to recharge the battery to its full capacity within one day, the result is often that the battery will continually be cycled between a 'partially charged' state and the 'end of discharge' state. This mode of operation (no regular full recharge) will destroy a lead-acid battery within weeks or months.

The Battery Life algorithm will monitor the state of charge of the battery and, if needed, day by day slightly increase the load disconnect level (i.e. disconnect the load earlier) until the harvested solar energy is sufficient to recharge the battery to nearly the full 100%. From that point onwards the load disconnect level will be modulated so that a nearly 100% recharge is achieved about once every week.

Programmable battery charge algorithm

See the software section on our website for details

Day/night timing and light dimming option

See the software section on our website for details

Programming, real-time data and history display options

- Modern Apple and Android smartphones, tablets, macbooks and other devices: see the SLI.Direct Bluetooth Smart dongle and the MPPT app discovery sheet for screenshots.
- ColorControl panel

SmartSolar Charge Controller	MPPT 75/10	MPPT 75/15	MPPT 100/15	MPPT 100/20	MPPT 100/20-48V
Battery voltage	12/24V Auto Select				48V
Rated charge current	10A	15A	15A	20A	20A
Nominal PV power, 12V 1a,b)	145W	220W	220W	290W	n. a.
Nominal PV power, 24V 1a,b)	290W	440W	440W	580W	n. a.
Nominal PV power, 48V 1a,b)	n. a.	n. a.	n. a.	n. a.	1160W
Max. PV short circuit current 2)	13A	15A	15A	20A	20A
Automatic load disconnect	Yes				
Maximum PV open circuit voltage	75V		100V		
Peak efficiency	98%				
Self-consumption	12V: 25 mA 24V: 15 mA			15mA	
Charge voltage 'absorption'	14,4V / 28,8V (adjustable)				57,6V (adj.)
Charge voltage 'float'	13,8V / 27,6V (adjustable)				55,2V (adj.)
Charge algorithm	multi-stage adaptive				
Temperature compensation	-16 mV / °C resp. -32 mV / °C				
Max. continuous load current	15A		20A		1A
Low voltage load disconnect	11,1V / 22,2V/44,4V or 11,8V / 23,6V/47,2V or Battery Life algorithm				
Low voltage load reconnect	13,1V / 26,2V/52,4V or 14V / 28V/56V or Battery Life algorithm				
Protection	Battery reverse polarity (fuse) / Output short circuit / Over temperature				
Operating temperature	-30 to +60°C (full rated output up to 40°C)				
Humidity	95%, non-condensing				
Data communication port	SLI.Direct (see the data communication white paper on our website)				
ENCLOSURE					
Colour	Blue (RAL 5012)				
Power terminals	6 mm ² / AWG10				
Protection category	IP43 (electronic components), IP22 (connection area)				
Weight	0,5 kg	0,6 kg		0,65 kg	
Dimensions (h x w x d)	100 x 113 x 40 mm		100 x 113 x 50 mm		100 x 113 x 60 mm
STANDARDS					
Safety	EN/IEC 62109-1, UL 1741, CSA C22.2				
1a) If more PV power is connected, the controller will limit input power.					
1b) The PV voltage must exceed Vbat + 5V for the controller to start. Thereafter the minimum PV voltage is Vbat + 1V					
2) A PV array with a higher short circuit current may damage the controller.					

SPECIFICATIONS

Nominal Voltage (V)	12V
*Capacity at C/100	137 Ah
*Capacity at C/20	125 Ah
*Capacity at C/5	110 Ah
Weight	85 lbs. (38.6 kg)
Plate Alloy	Lead Calcium
Posts	Forged Terminals & Bushings
Container/Cover	Polypropylene
Operating Temperature Range	-76°F (-60°C) - 140°F (60°C)

For Charging Parameters please refer to www.mkbattery.com
Click on Technical Data, then on Photovoltaic Charging Parameters in the PV/Solar section

Vent	Self-sealing
Electrolyte	Sulfuric acid thixotropic gel
Terminal	(B) T876



Rated UN2794, wet filled with acid

Made in the U.S.A. by East Penn Manufacturing Co, Inc.

* Capacities are based on peak performance.

Valve-Regulated, Gelled-Electrolyte Battery



DIMENSIONS

Inches (mm)

Length	13.58 (345 mm)
Width	6.77 (172 mm)
Height	11.42 (290 mm)

Gel Cycle Life vs Depth of Discharge at +25°C (77°F)
Based on BCI 2-hour Capacity

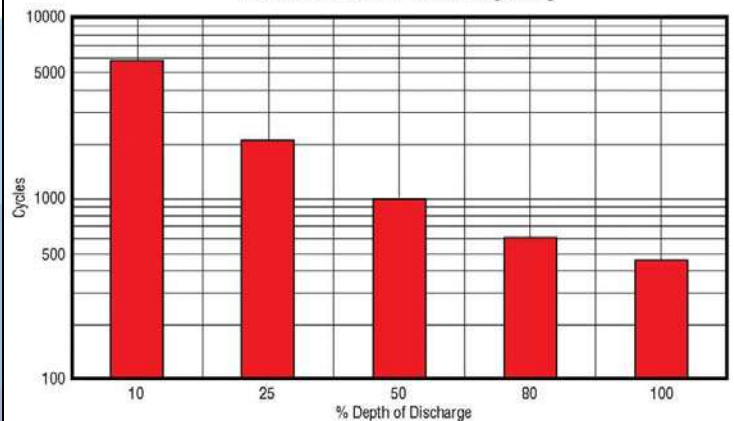

MK Battery

1631 South Sinclair Street • Anaheim, California 92806

Toll Free: 800-372-9253 • Fax: 714-937-0818 • E-mail: sales@mkbattery.com



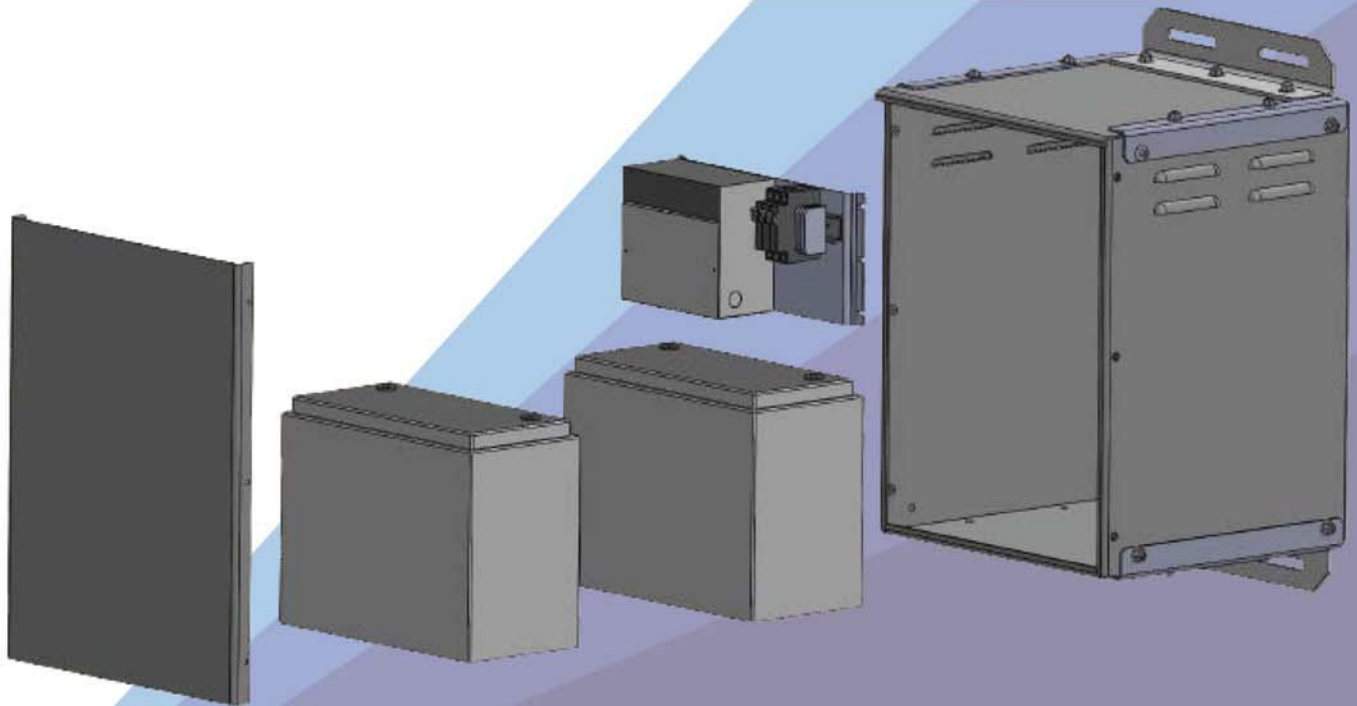
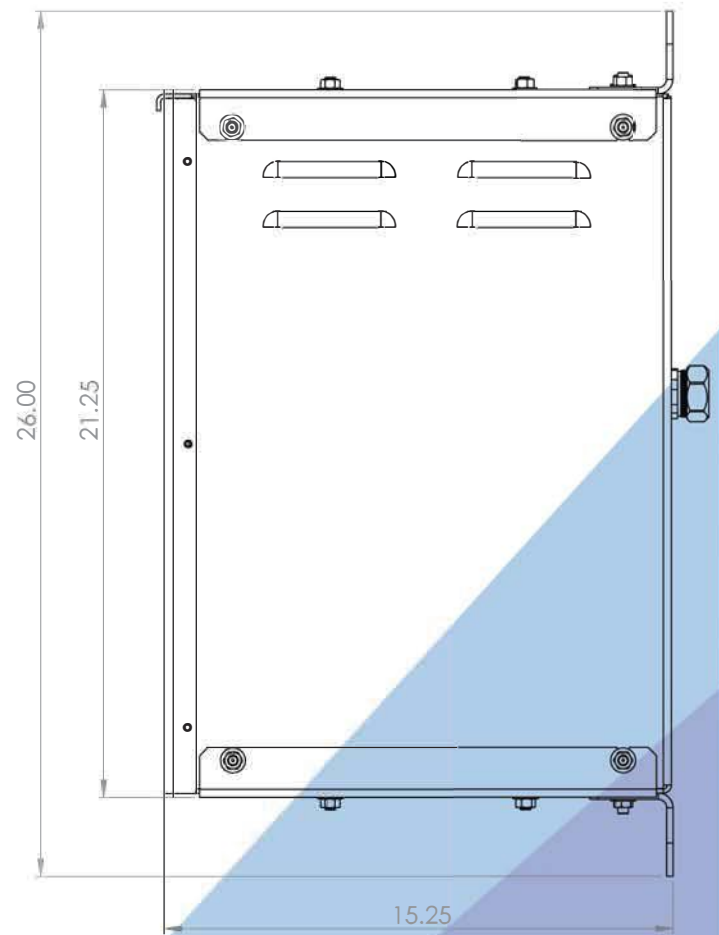
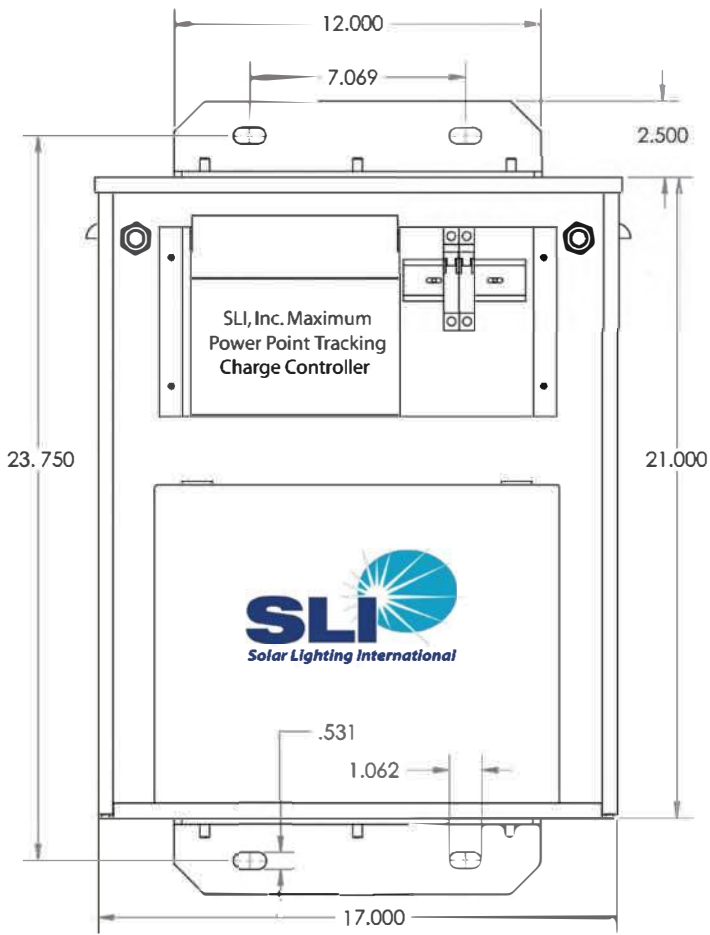

MINIATURE CIRCUIT BREAKER

Technical Data (MCB-AC/MCB-DC)

MCB

ISOLATOR

MCB-AC

Type	'B'	'C'	'D'	
Standard Conformity	IS/IEC60898-1-2002	CML-88858716		IS/IEC60947-3
Rated Current (In)	6-63A	0.5-125A	0.5-63A	25-125A
Rated Voltage AC (Ue)		240/415V		240/415V
Utilization Category				AC22A
Rated Frequency Hz		50Hz		50Hz
No. of Poles (Execution)	1P, 1P+N, 2P, 3P 3P+N & 4P	1P, 2P, 3p & 4P		
Rated Short Circuit Breaking Capacity	10kA	10kA	10kA	
Rated Insulation Voltage (Ui)		660V		660V
Magnetic Release Setting	(3-5)In	(5-10)In	(10-20)In	
Rated Impulse Voltage (Uimp)		6kV		6kV
Electrical/Mechanical Life <32A		30,000		30,000
>32A		10,000		10,000
Ambient Temperature		-5°C to +55°C		-5°C to +55°C
Energy Limiting Class		ELC 3		
Mounting		Clip on Din rail (35x7.5 mm)		Clip on Din rail (35x7.5 mm)
Line Terminal Capacity		35 mm ²		35 mm ²
Degree of Protection		IP 20		IP 20
Resistance to Shock		40mm free fall		40mm free fall

MCB-DC

Circuit Breakers for DC application are engineered to fulfill tough arc quenching conditions. DC MCB incorporates built in magnet to direct the arc into the arc quenching chamber.

Standard Conformity	IS/IEC60898-2-2002
Current Rating	0.5-63A
No. of Poles	1P & 2P
Voltage Rating	220V (max.)
Short Circuit Breaking Capacity	4kA



TEMPERATURES

Temperature deration

MCBs are calibrated at an ambient temperature of 30°C. In an industrial environment where ambient temperature is higher than the regulatory reference temperature of 30°C, the circuit breakers may be subjected to untimely tripping (nuisance tripping). At a temperature above 30°C the thermal release trips faster, behaving like a relay with a lower nominal current. It is therefore imperative to take into account nominal current derating if the circuit breaker is installed at a higher ambient.

The table gives the max. operating current referring to the different temperatures.

Temperature

In(A)	25°C	30°C	35°C	40°C	45°C	50°C
2	2.04	2	1.96	1.9	1.86	1.82
6	6.24	6	5.82	5.52	5.28	4.98
10	10.40	10	9.7	9.2	8.8	8.3
16	16.5	16	15.5	15	14.4	14.1
20	20.6	20	19.4	18.8	18	17.6
25	25.8	25	24.3	23.5	22.5	22
32	33	32	31.04	30.1	28.8	28.2
40	41.2	40	38.8	37.6	36	35.2
63	64.89	63	61.79	60	58	56.07

INSTALLATION

Installation Dimensions MCB (0.5 to 63A) / Isolator (25 to 125A)

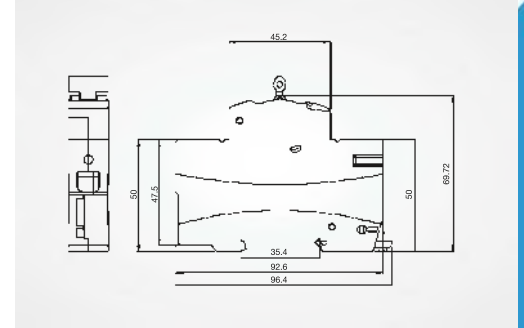
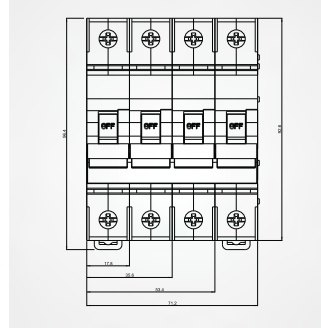

Installation Dimensions MCB (80 to 125A)

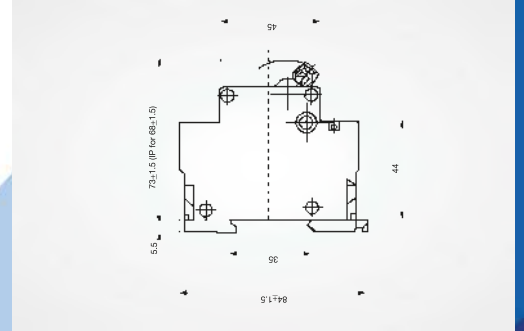
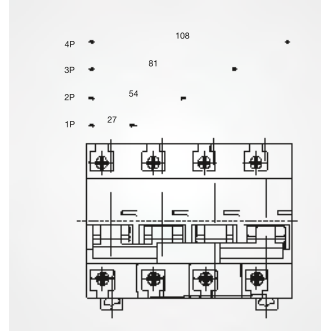

PART#	IMS STOCK CODE	BRAND	DESCRIPTION	AMPS / # POLES / MOUNTING OPTIONS	DIM (L)	DIM (W)	DIM (H)	WEIGHT
MCSMB1C0.5	0300-9324	MCG	MINI CIRCUIT BREAKER	0.5 AMP 1 POLE MCB DIN MOUNT	1p	0.5	DIN	0.26
MCSMB1C1	0298-9221	MCG	MINI CIRCUIT BREAKER	1 AMP 1 POLE MCB DIN MOUNTABLE	1p	1	DIN	0.269
MCSMB1C10	0300-9345	MCG	MINI CIRCUIT BREAKER	10 AMP 1 POLE MCB DIN MOUNTABLE	1p	10	DIN	0.26
MCSMB1C16	0305-3142	MCG	MINI CIRCUIT BREAKER	16AMP 1POLE MCB DIN MOUNTABLE	1p	16	DIN	0.267
MCSMB1C2	0300-9333	MCG	MINI CIRCUIT BREAKER	2 AMP 1 POLE MCB DIN MOUNTABLE	1p	2	DIN	0.267
MCSMB1C20	0300-9357	MCG	MINI CIRCUIT BREAKER	20 AMP 1 POLE MCB DIN MOUNTABLE	1p	20	DIN	0.269
MCSMB1C25	0300-9360	MCG	MINI CIRCUIT BREAKER	25 AMP 1 POLE MCB DIN MOUNTABLE	1p	25	DIN	0.271
MCSMB1C3	0300-9336	MCG	MINI CIRCUIT BREAKER	3 AMP 1 POLE MCB DIN MOUNTABLE	1p	3	DIN	0.262
MCSMB1C32	0300-9363	MCG	MINI CIRCUIT BREAKER	32 AMP 1 POLE MCB DIN MOUNTABLE	1p	32	DIN	0.269
MCSMB1C40	0300-9366	MCG	MINI CIRCUIT BREAKER	40 AMP 1 POLE MCB DIN MOUNTABLE	1p	40	DIN	0.282
MCSMB1C5	0300-9339	MCG	MINI CIRCUIT BREAKER	5 AMP 1 POLE MCB DIN MOUNTABLE	1p	5	DIN	0.262
MCSMB1C6	0300-9342	MCG	MINI CIRCUIT BREAKER	6 AMP 1 POLE MCB DIN MOUNTABLE	1p	6	DIN	0.258
MCSMB2C1	0300-9408	MCG	MINI CIRCUIT BREAKER	1 AMP 2 POLE MCB DIN MOUNTABLE	2p	1	DIN	0.518
MCSMB2C10	0300-9420	MCG	MINI CIRCUIT BREAKER	10 AMP 2 POLE MCB DIN MOUNTABLE	2p	10	DIN	0.509
MCSMB2C16	0305-3145	MCG	MINI CIRCUIT BREAKER	16AMP 2POLE MCB DIN MOUNTABLE	2p	16	DIN	0.522
MCSMB2C20	0300-9423	MCG	MINI CIRCUIT BREAKER	20 AMP 2 POLE MCB DIN MOUNTABLE	2p	20	DIN	0.525
MCSMB2C25	0300-9426	MCG	MINI CIRCUIT BREAKER	25 AMP 2 POLE MCB DIN MOUNTABLE	2p	25	DIN	0.538
MCSMB2C3	0300-9411	MCG	MINI CIRCUIT BREAKER	3 AMP 2 POLE MCB DIN MOUNTABLE	2p	3	DIN	0.509
MCSMB2C32	0300-9429	MCG	MINI CIRCUIT BREAKER	32 AMP 2 POLE MCB DIN MOUNTABLE	2p	32	DIN	0.531
MCSMB2C40	0300-9432	MCG	MINI CIRCUIT BREAKER	40 AMP 2 POLE MCB DIN MOUNTABLE	2p	40	DIN	0.566
MCSMB2C5	0300-9414	MCG	MINI CIRCUIT BREAKER	5 AMP 2 POLE MCB DIN MOUNTABLE	2p	5	DIN	0.518
MCSMB2C6	0300-9417	MCG	MINI CIRCUIT BREAKER	6 AMP 2 POLE MCB DIN MOUNTABLE	2p	6	DIN	0.507
MCSMB3C1	0300-9435	MCG	MINI CIRCUIT BREAKER	1 AMP 3 POLE MCB DIN MOUNTABLE	3p	1	DIN	0.765
MCSMB3C10	0300-9450	MCG	MINI CIRCUIT BREAKER	10 AMP 3 POLE MCB DIN MOUNTABLE	3p	10	DIN	0.76
MCSMB3C16	0305-3148	MCG	MINI CIRCUIT BREAKER	16AMP 3POLE DIN MOUNTABLE	3p	16	DIN	0.776
MCSMB3C20	0300-9453	MCG	MINI CIRCUIT BREAKER	20 AMP 3 POLE MCB DIN MOUNTABLE	3p	20	DIN	0.778
MCSMB3C25	0300-9456	MCG	MINI CIRCUIT BREAKER	25 AMP 3 POLE MCB DIN MOUNTABLE	3p	25	DIN	0.796
MCSMB3C3	0300-9438	MCG	MINI CIRCUIT BREAKER	3 AMP 3 POLE MCB DIN MOUNTABLE	3p	3	DIN	0.763
MCSMB3C32	0300-9459	MCG	MINI CIRCUIT BREAKER	32 AMP 3 POLE MCB DIN MOUNTABLE	3p	32	DIN	0.793
MCSMB3C40	0300-9462	MCG	MINI CIRCUIT BREAKER	40 AMP 3 POLE MCB DIN MOUNTABLE	3p	40	DIN	0.809
MCSMB3C5	0300-9441	MCG	MINI CIRCUIT BREAKER	5 AMP 3 POLE MCB DIN MOUNTABLE	3p	5	DIN	0.76
MCSMB3C6	0300-9447	MCG	MINI CIRCUIT BREAKER	6 AMP 3 POLE MCB DIN MOUNTABLE	3p	6	DIN	0.754



CERTIFICATE



This is to certify that

Custom Manufacturing Services, Inc.

142 Brick Street
Princeton, WV 24740
United States of America

with the organizational units/sites as listed in the annex

has implemented and maintains a **Quality Management System.**

Scope:

The provision of custom metal fabrication and systems level integration of electro-mechanical assembly.

Through an audit, documented in a report, it was verified that the management system fulfills the requirements of the following standard:

ISO 9001 : 2015

Certificate registration no.	10000410 QM15
Date of certification	2018-08-14
Valid until	2021-08-13



DQS Inc.

Brad McGuire
Managing Director

Accredited Body: DQS Inc., 1130 West Lake Cook Road, Suite 340, Buffalo Grove, IL 60089 USA





**Annex to certificate
Registration No. 10000410 QM15**

Custom Manufacturing Services, Inc.

142 Brick Street
Princeton, WV 24740
United States of America



Extended Location

Scope

**10002998
Custom Manufacturing Services, Inc.
400 Rogers Street
Princeton, WV 24740
United States of America**

The off-site at 400 Rogers Street, Princeton, WV performs the following primary functions: metal fabrication and assembly.